

Product Information

LTM 5 and LTM 10 electro-dynamic testing machine

CTA: 113389 113384



LTM 5 testing machine



LTM 10 testing machine

Range of application

The LTM is an electro-dynamic testing machine with a drive based on linear motor technology. ZwickRoell's new, patented drive concept enables the LTM to be used for dynamic, as well as static, materials and component testing. The low moving mass of the drive provides ideal conditions for fatigue and endurance testing.

With its oil-free drive technology, the electro-dynamic testing machine is clean and dependable for use, especially in the medical industry. Core applications include norm compliance testing of hip, knee and dental implants.

Other typical applications include fatigue and endurance testing on norm-defined plastic and composite specimens, or on bonded components such as rubber/metal joints. Fracture mechanics investigations can also be carried out on aluminum and plastic CT and SEB specimens.

Intuitive and informative operation via testXpert R and testXpert III software makes the LTM a genuine all-rounder, also suitable for research and training at educational institutions.

Features

- Optimum performance through patented cylindrical drive-based technology.
- From high dynamic through to low speed testing rates.
- Integrated displacement measurement with excellent positioning, precision and accuracy.
- Fatigue-resistant, wear-free braking system for piston-clamping.
- High-precision, fatigue-resistant 2-column test frame with integrated T-slotted platform and collection trough.
- Intelligent cooling system with automatic output-dependent control.
- LTM supplied with integrated cooling system as standard. Optional connection to preinstalled cooling systems.
- Precise control via 10kHz data-capture frequency, enabling rapid reaction to spontaneous events.
- Electrically interlocked safety enclosure for compliance to the EC Machinery Directive.

Product Information

LTM 5 and LTM 10 electro-dynamic testing machine

Advantages

- high dynamic performance, thanks to low moving mass
- wide speed-range enables dynamic fatigue testing plus slow static testing
- maintenance and adjustment-free brakes for mechanical piston-clamping
- no additional pneumatic, coolant, oil, etc. supply feeds required
- motor-driven traverse adjustment, for ergonomic operation
- safe setup mode as per EN 60204-1 via speed reduction to 10 mm/s
- precision low-wear piston-rod bearings
- simple manual traverse locking via hand lever with electrical monitoring
- long piston-stroke (60 mm) enables wide variety of tests
- operator-friendly testXpert R testing software with pre-adjusted controller settings and availability of free controller definition for individual testing requirements
- intelligent testing software featuring intuitive operation - testXpert R for dynamic tests and testXpert III for static tests
- flexible use of specimen grips and fixtures from the entire dynamic product range

CTA: 76019 77492

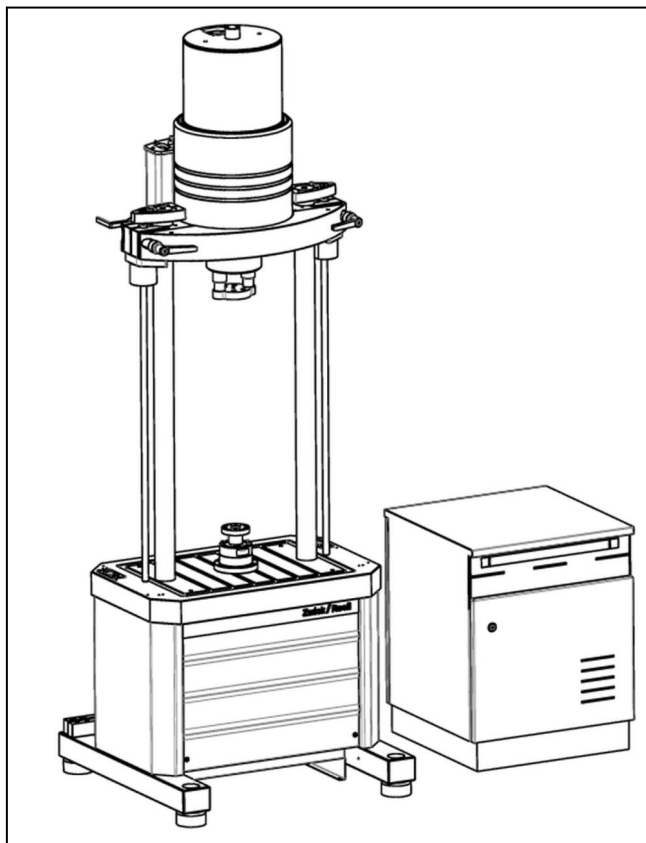

LTM 5 testing machine with electronics

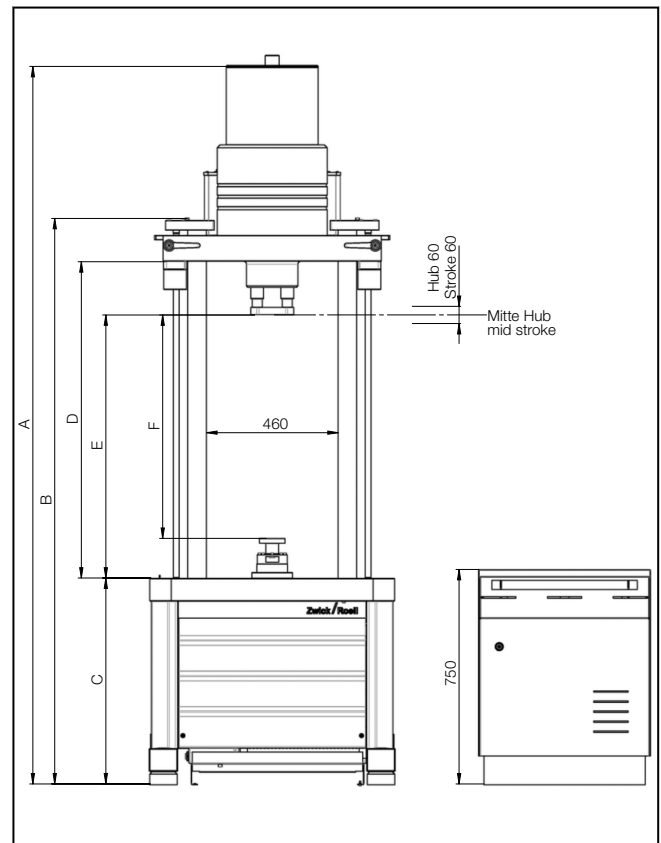

Drawing: LTM testing machine

Technical data

Type	LTM 5 Standard	LTM 5 + 250 mm ¹⁾	LTM 10 Standard	LTM 10 + 250 mm ²⁾	
Item No.	1008107	3001848	1008108	3001847	
F _{max} , dynamic	±5	±5	± 10	± 10	kN
F _{max} , static continuous	±3.5	±3.5	± 7	± 7	kN
Piston stroke	60	60	60	60	mm

All data at ambient temperature.

We reserve the right to make technical changes in the course of ongoing development.

Product Information

LTM 5 and LTM 10 electro-dynamic testing machine

Type Item No.	LTM 5 Standard 1008107	LTM 5 + 250 mm ¹⁾ 3001848	LTM 10 Standard 1008108	LTM 10 + 250 mm ²⁾ 3001847	
Positioning and repeat accuracy	±2	±2	±2	±2	µm
Speed range	1	1	1	1	mm/min
	1.5	1.5	1.0	1.0	m/s
Maximum frequency ³⁾	100	100	100	100	Hz
Noise level at 1 meter distance, max. ⁴⁾	< 68	< 68	< 68	< 68	dB(A)
Load frame					
Overall height of testing machine, max. (A) ⁵⁾	2510	2760	2715	2965	mm
Overall height of test frame, max. (B)	1980	2230	1980	2230	mm
Overall width	860	860	860	860	mm
Overall depth	850	850	850		mm
Height of mounting table (C)	720	720	720	720	mm
Column diameter	65	65	65	65	mm
Test-area height, max. (D) ⁵⁾	1106	1356	1106	1356	mm
Frame stiffness at 1000mm crosshead separation	300	300	300	300	kN/mm
Total weight ⁶⁾	941	966	1040	1065	kg
Working area					
Working-area width	460	460	460	460	mm
Working area width without load cell, max. (E) ⁵⁾⁷⁾	920	1170	920	1170	mm
Working area height with load cell, max. (F) ⁵⁾⁷⁾	781	1031	781	1031	mm
Top crosshead adjustment	Motorized				
Top crosshead clamping	Manual				
Crosshead clamping electrically monitored	Yes, with signal indicator				

1) Extended load frame (required for use with a temperature chamber)

2) Extended load frame - required when using a temperature chamber

3) Depending on load ratio (r-ratio) and test amplitude

4) Depending on output required, environment, testing arrangement, testing type, frequency and specimen type. Measured at 1m distance, free field, analog to DIN EN ISO 11205

5) Highest crosshead position

6) Testing machine only, without electrical cabinet, accessories and options

7) Median piston position

testControl II measurement and control electronics	
Control frequency	10 kHz
Measured value acquisition	10 kHz, 24 bits, arithmetical
Slots	5 x module bus
PC interface	GigaBit Ethernet

Product Information

LTM 5 and LTM 10 electro-dynamic testing machine

testControl II measurement and control electronics			
Integrated safety concept	- 2-channel specification for maximum safety - interface for interlocked safety doors - Emergency Stop link interface		
Display-equipped remote control unit	set-up or testing mode - Emergency Stop button key-switch for switching between setup and testing modes		
Dimensions			
Height	750		mm
Width	600		mm
Depth	600		mm
Weight approx.	102		kg
Length of cable between LTM & testControl II	500		mm
Protection class	IP 54		

Installation conditions

Type	LTM 5	LTM 10	
Operating temperature	+10 to +30	+10 to +30	°C
Storage temperature	-25 to +50	-25 to +50	°C
Humidity (non-condensing)	20 to 90	20 to 90	%
Electrical connection			
Power supply voltage	400	400	V, 3 Ph/N/PE
Power frequency	50/60	50/60	Hz
Output	11.1	22.17	kVA
Back-up fuse	16 T	32 T	A
CEE plug with 5 m cable	16	32	A
Integrated ambient air cooling unit			
Exhaust air temperature ¹⁾²⁾	0.5-2.5	0.5-5	kW
Max. air circulation volume	2360	2360	m ³ /h
Minimum spacing rear of machine - wall	600	600	mm

1) Depending on output required

2) In conjunction with integrated cooling unit using ambient air, Item No. 3001889

Load cell

Description	Item number
Nominal force ± 5 kN ¹⁾	1011454
Nominal force ± 10 kN ¹⁾	1011455

1) Accuracy Class 0.5 to EN ISO 7500-1

Product Information

LTM 5 and LTM 10 electro-dynamic testing machine

Safety devices

Description	Item number
LTM 5 and 10 kN: 4-sided safety device made of steel sheet, front safety door with Makrolon panel, electrical monitoring and interlocking, standard height	3001838
LTM 5 and 10 kN: 4-sided safety device made of steel sheet, front safety door with Makrolon panel, electrical monitoring and interlocking, increased-height version + 250 mm ¹⁾	1020533

1) Extended load frame - required for use with a temperature chamber

Increased total weight

Suitable for applications with higher frequencies and stiff specimens, plus long strokes with high acceleration

Description	Item number
Total weight + approx. 600 kg; height A, B, C + approx. 180 mm	3001891

Air-spring elements

For reduction of vibrations, shocks and structure-borne noise

Description	Item number
Height A, B, C + approx. 50 mm	3001895

Cooling units for LTM 5/10

ZwickRoell has the following options to suit different ambient conditions in the testing laboratory

Description	Item number
Integrated ambient-air cooling-unit (standard) <ul style="list-style-type: none">no additional pneumatic, coolant, oil etc. supply connections requiredmaximum energy transfer to environment:<ul style="list-style-type: none">LTM 5 -> 2.5 kW¹⁾LTM 10 -> 5.0 kW¹⁾	3001889
Integrated unit for coolant supply connection (option) <ul style="list-style-type: none">suitable for maintaining low room-heating and noise levelfor connection to coolant supply by customer	3001890
External coolant system for LTM (option) <ul style="list-style-type: none">suitable for maintaining low room-heating and noise levelspecifically for use at high ambient temperaturesfor covered installation outside test area	087110

1) Depending on output required